

Spontaneous Creation of the Universe Ex Nihilo

Maya Lincoln* and Avi Wasser†
University of Haifa, Haifa 31905, Israel

Questions regarding the formation of the Universe and ‘what was there’ before it came to existence have been of great interest to mankind at all times. Several suggestions have been presented during the ages - mostly assuming a preliminary state prior to creation. Nevertheless, theories that require initial conditions are not considered complete, since they lack an explanation of what created such conditions. We therefore propose the ‘Creatio Ex Nihilo’ (CEN) theory, aimed at describing the origin of the Universe from ‘nothing’ in information terms. The suggested framework does not require amendments to the laws of physics: but rather provides a new scenario to the Universe initiation process, and from that point merges with state-of-the-art cosmological models. The paper is aimed at providing a first step towards a more complete model of the Universe creation - proving that creation Ex Nihilo is feasible. Further adjustments, elaborations, formalisms and experiments are required to formulate and support the theory.

I. INTRODUCTION

Questions regarding the formation of the Universe and ‘what was there’ before it came to existence have been of great interest to mankind at all times. Many suggestions have been presented during the ages - mostly assuming a preliminary state prior to creation.

Currently, the most commonly accepted state-of-the-art theory for the Universe creation is the hot Big-Bang theory, stating that the Universe has expanded from a primordial hot and dense initial condition. The Big-Bang theory has been extremely successful in correlating the observable properties of the Universe with the known underlying physical laws [1]. Yet, this theory cannot describe what came *before* the Big-Bang event and also what happened during the first miniscule time-fraction after the initial Big-Bang (Planck time).

In general, any model of the Universe creation that involves preliminary conditions or requires an initial state is incomplete since it lacks an explanation of what created these initial conditions. Therefore, we adopt the vision of a “flash of Universe appearing from nothing” [2], assuming that the starting phase of the Universe adheres with the “principle of ignorance,” and that “singularity is the ultimate unknowable, and therefore should be totally devoid of information” [3].

Only a few theories were suggested in accordance to this line of thought. Vilenkin suggested a cosmological scenario for the creation of the Universe from “nothing” (the author’s words) [4, 5]. His proposed scenario interacts gravitational and matter fields, and a symmetric vacuum state that has a nonzero energy density. Therefore, the initial state does not, in fact, represent an absolute, pure, ‘nothing.’ Another work - by Tryon, suggested that our Universe was created spontaneously from nothing (“Ex-Nihilo”) as a “quantum fluctuation of some pre-existing true vacuum, or state of nothingness” [2, 6]. Following this line of thought, the Universe is a fluctuation of the vacuum in the sense of the quantum field theory. Therefore, the initial state is not property-less, and it requires an explanation of how fluctuations can evolve from ‘nothingness.’ In the same manner, also theories that support the emergence of the Universe by quantum tunneling[7], from vacuum in quantum-cosmology or from the string perturbative vacuum [8–11] encounter the above mentioned limitations.

To overcome these deficiencies, we suggest a new theory, ‘Creatio Ex Nihilo’ (CEN), aimed at describing the origin of the Universe from ‘nothing’ in information terms.

The notion of bit-based information at the core of the Universe evolution is not new. This trend suggests that the physical world is “made of information, with energy and matter as incidentals” [12]. Accordingly, information gives rise to “every it - every particle, every field of force, even the spacetime continuum itself” [13]. Therefore, what we refer to as reality, “arises in the last analysis from the posing of yes-no questions” [13]. Vedral, on the same line, claimed that information is the building block from which everything is constructed and that all natural phenomena can be explained in information terms [14]. Information, he argues, is the only appropriate entity on which the ultimate theory of everything should be based.

*Electronic address: maya.lincoln@processgene.com

†Electronic address: awasser@haifa.ac.il

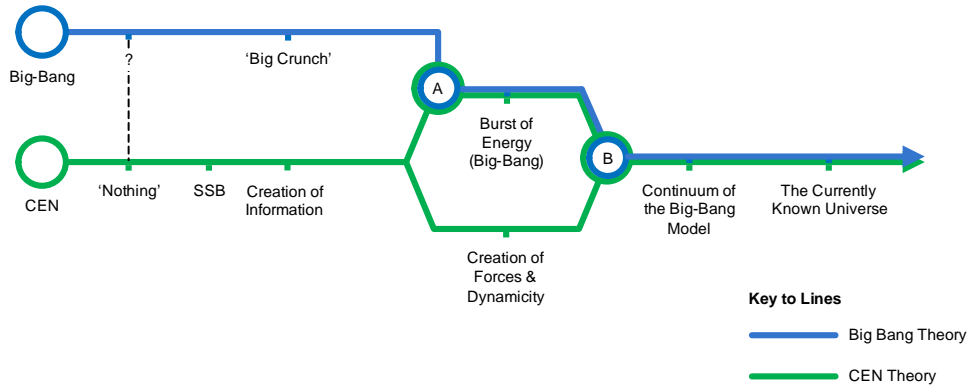

Figure 1: A schematic route map of the Big-Bang theory and the CEN theory. The blue time-line represents major milestones addressed by the Big-Bang theory, and the green line represents those of the CEN theory. Joints A and B point out alternative merge points.

In this work we further elaborate these concepts, and show how bit-based information, dimensions, forces and dynamicity can evolve from a ‘null’ information state. CEN does not require any amendments to the laws of physics: it features a new scenario to the Universe initiation event, and from that point merges with state-of-the-art cosmological models.

The paper is aimed at providing a *first step* towards a more complete model of the Universe creation - eliminating the requirement for preliminary conditions. The emphasis of the paper and its main goal is proving how the Universe creation could occur Ex Nihilo in information terms. Further adjustments to the physical laws, elaborations, formalisms and experiments are required to formulate and support the theory, and are not within this paper’s scope.

II. CREATIO EX NIHILO

To explain the suggested theory, CEN, we outline a schematic route map consisting of two ‘traffic’ lines. The first line features the Big-Bang stream of research and the second presents the CEN theory (see illustration in Fig. 1). The Big-Bang theory commences from an unknown state followed by a ‘Big-Crunch’ - a hot and dense initial condition. CEN, on the other hand, assumes initiation at a state of ‘nothing’ which is then transformed into ‘information’ due to a Spontaneous Symmetry Break (SSB). Following the formation of information, and in order to explain the further steps in the Universe creation process, we present two alternatives for integrating CEN with the Big-Bang theory. According to the first option (merge point A), CEN amalgamates with the Big-Bang theory through a conversion of information into energy. Alternatively, the theories merge at point B, with the addition of an additional phase in CEN, in which forces and dynamicity naturally emerge from the state of ‘information.’ After either of the merge points, the Universe continues its development according to the Big-Bang theory.

In the following sections we elaborate on the CEN theory and review its major milestones.

A. In the Beginning

According to the newly suggested theory, CEN, in the beginning there was *nothing* – no material, no energy, no space and no time. This situation was fully symmetric with no entropy. Therefore, this initial state was allegedly static, with no motive for change.

In terms of information, ‘nothing’ is equivalent to an *infinite number* of simultaneous *Nullifying Information Elements (NIEs)* - information elements that co-exist simultaneously and cancel each other. Each such element represents either a *being* - existence of something, or the cancellation of that existence, *no-being*. In information terms, such NIEs resemble the notion of “*bits*.” For convenience, we will use this term throughout the paper, while naming the information element that represents existence as *bit+* and the one that represents no-existence as *bit-*. The number of bits of each type is infinite. Each *bit+* element can co-exist simultaneously with each *bit-* element, or equivalently, can co-exist with *all* of the *bit-* elements with an equal probability, and vice versa. To illustrate the above notion, an infinite number of simultaneous, co-existing, *bit+* elements and *bit-* elements are illustrated in Fig. 2.

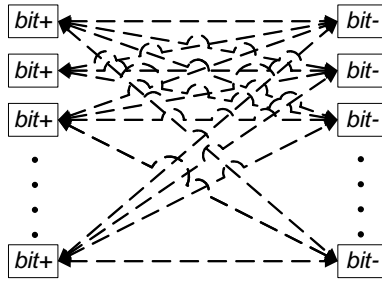

Figure 2: ‘Nothing’ in information terms. In terms of information, ‘nothing’ is equivalent to an infinite number of simultaneous NIEs. The dashed arrows symbolize possible co-existence relationships between $bit+$ and $bit-$ pairs.

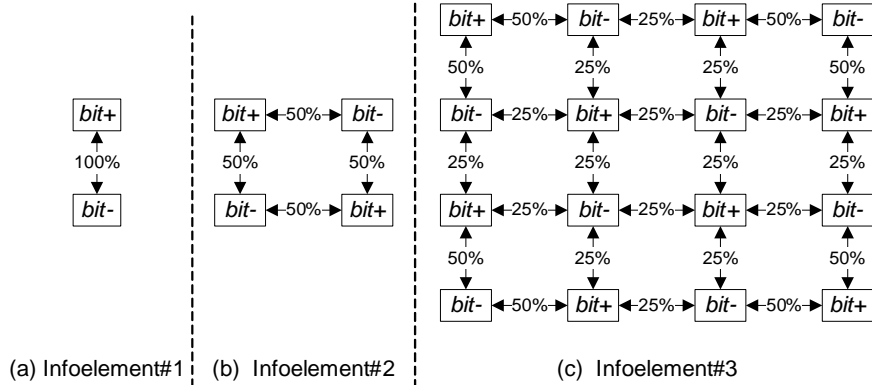

Figure 3: Information formation as a result of a Spontaneous Symmetry Break. Each element is related to more than one Nullifying Information Elements with relative probabilities that sum to 100%. In part b, for example, two $(bit+, bit-)$ pairs are reordered so that each $bit-$ element is related (co-exists) to each of the $bit+$ elements with an equal probability of 50%, and each of the $bit+$ elements are related to the $bit-$ elements in a similar manner. Part a and part c represent additional examples to possible infoelement structures.

B. The Creation of Information

The co-existence of opposite nullifying elements derives a *matching necessity* within the compendium of simultaneous NIEs. Any specific match of opposite NIEs would influence other matches, by reducing the set of available matching options. Assuming an *infinite* amount of NIEs of each type, each group of elements of the same type remains equivalent with the potential addition of several other elements. These *potentially additional elements* also require matching, which can be carried out in different patterns, e.g. by matching to an un-matched potentially additional opposite NIE, or by replacing an already matched opposite NIE. Therefore, the potentially additional NIEs can cause a *Spontaneous Symmetry Break (SSB)* - by changing the matching arrangement of other NIEs which are matched to other elements, re-causing additional changes, etc.

The above description is in-line with the description of SBB in literature. First, the actual breaking can happen only if some asymmetrical causal factors, such as random perturbations or fluctuations are introduced to the model [15]. In our model the potentially additional NIEs cause an SSB by introducing potential random fluctuations. Second, in the “no boundary conditions” cosmology, favored by several modern cosmologists, there is also no information in the initial conditions - that are entirely symmetrical [16], and therefore all information must arise through symmetry breaking [17].

Due to the spontaneous symmetry break, new relationships between NIEs are generated. The simplest example is the formation of new pairs of opposite NIEs. Other examples can be more complex, for instance, when each element is related to more than one NIEs with relative probabilities (or weights) that sum to 100%, as illustrated in Fig. 3. We name each such separate group of NIEs as “infoelement,” a combination of the words “information” and “element.”

It can be argued that some infoelements generated as a result of the initial SSB were not necessarily symmetrical, as illustrated in Fig. 4. In general, it is maintained that an asymmetry can only be resulted from a preceding asymmetry [18]. Nevertheless, when an SSB is caused by fluctuations, asymmetric systems can still be resulted - due to the following arguments: first, when eliminating the random perturbations, the ‘broken symmetrical’ solution

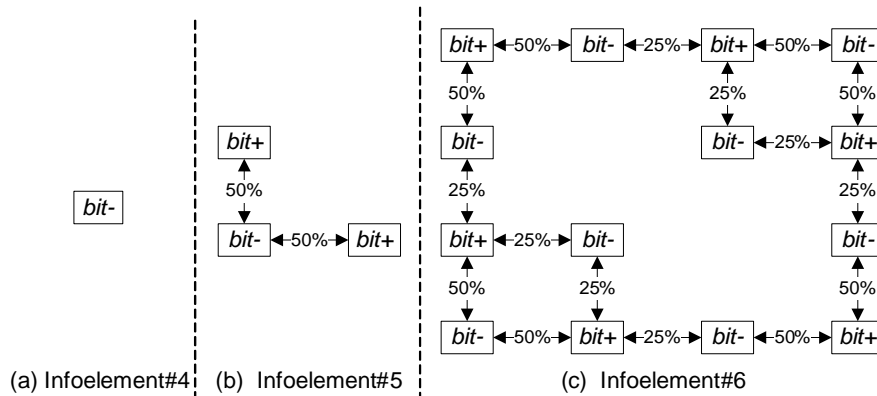

Figure 4: Examples of asymmetrical and imbalanced infoelements. Some infoelements generated as a result of the initial SSB were not necessarily symmetrical, e.g.: (1) an unmatched NIE (part a); (2) an infoelement with an odd-number of NIEs (part b); or a less symmetrical infoelement (part c). Part a and part c represent additional examples to possible infoelement structures.

comprises a set of degenerate ground states, each of which breaks the symmetry but all of which together preserve it; and second, if we consider the random perturbations, then “no asymmetry in” is no longer true [15]. Note that asymmetric infoelements are also imbalanced – since some of their NIEs are matched to their opposite NIEs with a cumulative probability of less than 100%. From this reason, such asymmetric infoelements will ‘tend’ to change, in order to complete their ‘loose ends.’

The new organizations of NIEs represent *information*. Therefore, the SSB is actually the cause for the *creation of information*.

Additionally, it can be noted that due to the above described process, each of the infoelements, resulted from the SSB, consists its own intrinsic *laws* of organization. For example, the organization of NIEs in ‘infoelement#3’ (Fig. 3a) implicates that ‘corner’ elements are related only to two other elements with probability of 50%; ‘internal-frame’ elements are related to three other elements with probabilities of 25%, 25% and 50%; and ‘internal’ elements are related to four other elements with probability of 25% each. In addition, there are also *relativity relationships* among each type of infoelements. For example, it can be indicated that ‘frame’ elements of infoelement#2 have ‘stronger’ relationships to each other comparing to those of infoelement#3.

Note that the *separability* between infoelements may not be as clear-cut as presented in the above examples (Fig. 3 and Fig. 4). NIEs of some infoelements may be connected also to ‘external’ NIEs (that belong to other infoelements) with very low probabilities, and in this ‘non-ideal’ case, separability is only an approximation. This situation resembles a song played on the radio – the song seems separate for us although we hear some background noises as well. Having said that, for simplicity only, and without limiting the proposed theory, we will continue referring to infoelements as purely separated information chunks.

In addition to separability and organization formation, the SSB is also responsible for the creation of *dimensions*. For instance, in Fig. 3, infoelement#3 and infoelement#2 can be both interpreted as two-dimensional information compounds, whereas infoelement#1 can be interpreted as a one-dimensional information compound. Note that in this example, there is no meaning for infoelements with three or more dimensions (e.g., a three-dimensional ‘cube’ of an equal number of *bit-* and *bit+* elements can be represented in this example as a ‘flattened’ cube with two dimensions).

C. Integration Option A - Conversion of Information into Energy

At this phase (merge point A in Fig. 1), following the formation of information, we present an option for integrating CEN with the Big-Bang theory. We rely on the notion that information and energy are closely related [12, 19], and that information can even be converted into energy [20]. Taking these notions one step forwards, if information is a *form of energy*, then CEN provides an explanation to the preliminary state and the most initial time segment of the Big-Bang, as an energy burst that was ignited ‘Ex Nihilo.’ From this phase of energy creation, the Universe continues developing according to the common Big-Bang model (energy is converted into various subatomic particles, and so on).

The newly suggested theory has the following advantages over the Big-Bang singularity notion: first, it does not require an explanation of what came *before* and what *caused* the initial state of singularity; and secondly, it does not require any initial conditions (e.g. the existence of condensed material or energy).

D. Integration Option B - the Emergence of Forces, Energy and Dynamicity

In option B we present an additional phase in CEN, in which forces and dynamicity naturally emerge from the state of 'information.' To facilitate the discussion, from this point on, we will refer to the compendium of all NIEs and their relationships as the 'Universe platform' - the most basic entity from which the Universe, as we know it, has evolved.

After the first, initial SSB, the constant presence of potentially additional NIEs continuously causes information changes and generates additional SSBs, each affecting some or all of the relationships between NIEs. These potentially additional NIEs violate the information balance, causing information changes. Changes are carried out based on the 'aspiration' of each NIE to reach a complete match with opposite NIEs. This mechanism is the source of *dynamicity* in the Universe platform, and the *dynamicity laws* are based on the above NIE balance aspiration. The mathematics of the exact dynamicity in the Universe platform is beyond the scope of this paper.

It is possible to consider the matching relationships between NIEs as *forces* that operate on the NIEs (to maintain their match). According to this description, each NIE has a *potential energy*, determined by the NIE's relative 'position,' meaning, its structure of relationships to other NIEs. When information is changed due to potentially additional NIEs, these changes are in accordance with the current force fields. In other words, when changes occur, the connecting forces between NIEs are expressed, with strength relative to the relationship probability. For example, in Fig. 3 the connections of Infoelement #2 are weaker (with lower probabilities) than those of Infoelement #1, and therefore Infoelement #2 will tend to break apart more easily due to potentially additional NIEs or additional SSBs. The matching *propensity* between NIEs is therefore the source of forces in the Universe platform.

The emergence of forces and dynamicity explain the source of energy in the Universe. Following this phase, CEN and the Big-Bang can integrate (merge point B in Fig. 1), and the Universe continues to evolve according to the Big-Bang theory.

1. The Universe as a Self-Excited Machine

From a philosophical viewpoint, we can conceive the Universe platform as a *self-excited machine* as follows. We can refer to the dynamicity laws in the Universe platform as the '*code of the Universe*' or the '*code of nature*.' In the beginning, the hypothetical Universe machine is self-ignited from 'nothing.' In the next phases, it 'holds' at each time the current Universe state (information), which encapsulates the probabilities of the next arrangement. An input of potentially additional NIEs triggers the '*reading*' of the code of the Universe/nature. As a result, the code is executed, changes are 'computed' and implemented - in terms of new relationships between NIEs, and as a consequence the machine 'outputs' the next Universe state (information).

III. EVIDENCE AND SUPPORT

This section presents evidence and experiments that support CEN's predictions. Some of the supporting phenomena are not predicted by any other theory in physics, hence emphasizing CEN's importance.

CEN is supported by the current laws of physics as well as by state-of-the-art experiments in the following ways:

1. The second law of thermodynamics. According to CEN, every change in the Universe is a result of symmetry reduction. This notion is supported by the second law of thermodynamics, according to which the entropy of an isolated system never decreases, because isolated systems spontaneously evolve towards thermodynamic equilibrium - the state of maximal entropy.

2. Virtual particles in vacuum. According to quantum electrodynamics (QED) and quantum chromodynamics (QCD), virtual particle pairs are continuously being created and annihilated in the vacuum. These virtual particles can be revealed in several experiments, for example, when placing two uncharged metallic plates in the vacuum (the Casimir effect).

This phenomenon is predicted by CEN. In fact, CEN is the only theory that predicts the exact mechanism responsible for this phenomenon. In CEN terms, these virtual particles are referred to as "potentially additional elements" that appear from 'nothing' and nullify each other (see Section B). Note that although in Section B the potentially additional elements are presented as 'bits,' the same mechanism allows also the appearance of nullifying bit compounds, like virtual particle pairs. This is an integral process in CEN that happens on a regular basis, and everywhere in space.

Moreover, according to CEN, potentially additional elements are served as *triggers for changes* in the Universe. This notion is supported by experiments in which virtual particles serve as triggers to physical processes. For example,

β - decay (in which a neutron decays to a proton, an electron, and an anti-neutrino) is carried-out via a virtual (mediating) W boson. In fact, as stated in [21], most particle processes are mediated by virtual-carrier particles.

3. Matter and anti-matter. The existence of matter and antimatter is a built-in property in CEN. According to CEN, the Universe was formed by bits and anti-bits, or particles and anti-particles (see above). In addition, the first infoelements could represent information and anti-information (the existence of 'something' and the non-existence of this 'something').

CEN also predicts the creation of matter and anti-matter from the vacuum in the following way. According to CEN, matter and antimatter can be originated as virtual particle pairs (potentially additional elements), and become "real" due to their attachment to information in the Universe, by causing a symmetry break. This notion of matter and antimatter creation from the vacuum is supported by experiments. For example, the work in [22] show how it is possible to generate matter and antimatter from the vacuum using high-energy electron beam combined with an intense laser pulse.

CEN can also provide an explanation to the observed matter and antimatter asymmetry (the excess of baryonic matter over antibaryonic matter) in the following way. First, CEN allows a non-equal number of particles vs. anti-particles at the initial state of the Universe (the state after the first SSB). Second, even if the Universe began with an equal amounts of matter and antimatter, at any later time, a potentially additional element (in this case-particle) may either nullify an anti-particle or join to the information in the Universe - in both cases leaving the Universe with unequal amounts of baryonic and antibaryonic matter. In principle, the processes of both nullification and addition of particles/antiparticles from and to the Universe is symmetric (should involve both matter and anti-matter with equal probability). Nevertheless, at a limited time period (as opposed to infinity), there is a non-zero probability for unequal number of nullifications and additions of antimatter vs. matter - which can cause a noticeable amount of matter over antimatter in the Universe.

In addition, experiments show that the excess of baryons over antibaryons, known as 'baryon number,' is constant. According to CEN, this number can marginally change in time, but this change is unlikely since there is an equal probability of matter and anti-matter nullification and addition. Therefore, in practice, the baryon number should be relatively fixed (minor changes will not be noticeable in the Universe).

4. Symmetry in the Universe. In general, CEN predicts an inherent symmetry in the Universe which constantly breaks. A great number of phenomena demonstrate vast symmetry in the Universe, and a great number of physical processes involve symmetry breaks. In fact, "all the physics of elementary particles, relies heavily on the ideas of symmetry and broken symmetry" [23].

5. Non-local influences. Experiments in quantum mechanics demonstrate the existence of non-local influences on particles and systems, e.g. due to particle entanglement [24]. CEN includes a built-in mechanism for non-local influences, and hence supports these experiments. According to CEN, all data in the Universe is interconnected and can be influenced by any change of information. SSBs, for example, can change the balance (structure) of several disconnected infoelements at the same time.

In addition to the above evidence and experiments that support CEN's predictions, there is also a theoretical consideration that prefers CEN over other Universe creation theories, and specifically over the initial Universe state sustained by the Big-Bang theory. CEN introduces a much *simpler* model to the initial state of the Universe due to the following reasons: (1) it is the *only* theory that does not require any prior initial state; and (2) it does not require an inflation phase. Therefore, according to Occam's raser - CEN is a more adequate theory for the initial Universe formation event than the Big-Bang theory that assumes a preliminary primordial hot and dense state - with an unknown origin.

IV. DISCUSSION AND FUTURE WORK

This paper presents a model for the Universe creation 'Ex-Nihilo.' The proposed theory's main advantage is that it does not require any explanations of the physics *prior* to the Universe creation. This stream of research can also provide an explanation to several unexplained phenomena, such as the second law of thermodynamics, the existence of virtual particles in vacuum, the source of symmetry in the Universe, the evolution of matter and anti-matter, and non-local influences in quantum mechanics.

The paper provides a *first step* towards a more complete model of the Universe creation - proving that creation Ex Nihilo is feasible. Further adjustments, elaborations, formalisms and experiments are required to formulate and support the theory. Two of such elaborations include: (1) formulating the mathematics of the dynamicity laws in the Universe platform; and (2) modeling specific mechanisms responsible for the evolvement of observed phenomena in the Universe, and in particular life itself. Such future research could demonstrate how complex and unpredictable phenomena can be generated from a small set of rules, and how it is possible to simulate dynamic life and other

computational processes from a small amount of initial information. Possible directions for such future research may be based on the discovery of information structures that maintain 'life' properties such as 'survival,' 'growth,' and 'duplication' during changes in the Universe; or representing the involvement of information in the Universe either as an extended case of a cellular automaton, or as an artificial neuron network.

-
- [1] M. Griffiths and C. Oliveira, "The big bang—a hot issue in science communication," *Communication Astronomy with the Public Journal*, vol. 10, p. 7, 2010.
- [2] E. Tryon, "Is the universe a vacuum fluctuation," *Nature (London)*, v. 246, no. 5433, pp. 396-397, vol. 246, no. 5433, 1973.
- [3] S. Hawking, "Breakdown of predictability in gravitational collapse," *Physical Review D*, vol. 14, no. 10, p. 2460, 1976.
- [4] A. Vilenkin, "Creation of universes from nothing," *Physics Letters B*, vol. 117, no. 1, pp. 25-28, 1982.
- [5] A. Vilenkin, "Birth of inflationary universes," *Physical Review D*, vol. 27, no. 12, p. 2848, 1983.
- [6] E. Tryon, "What made the world?," *New Scientist*, vol. 101, pp. 14-16, 1984.
- [7] J. Hartle and S. Hawking, "Wave function of the universe," *Physical Review D*, vol. 28, no. 12, p. 2960, 1983.
- [8] M. Gasperini and G. Veneziano, "Pre-big-bang in string cosmology," *Astroparticle Physics*, vol. 1, no. 3, pp. 317-339, 1993.
- [9] M. Gasperini and G. Veneziano, "Inflation, deflation, and frame-independence in string cosmology," *Modern Physics Letters A*, vol. 8, no. 39, pp. 3701-3713, 1993.
- [10] M. Gasperini and G. Veneziano, "Dilaton production in string cosmology," *Physical Review D*, vol. 50, no. 4, p. 2519, 1994.
- [11] R. Brustein and G. Veneziano, "The graceful exit problem in string cosmology," *Physics Letters B*, vol. 329, no. 4, pp. 429-434, 1994.
- [12] J. Bekenstein, "Information in the holographic universe," *Scientific American*, vol. 289, no. 2, pp. 58-65, 2003.
- [13] J. Wheeler, "Information, physics, quantum: The search for links. in (w. zurek, ed.) complexity, entropy, and the physics of information. redwood city," *CA: Addison-Wesley. Cited in DJ Chalmers,(1995) Facing up to the Hard Problem of Consciousness, Journal of Consciousness Studies*, vol. 2, no. 3, pp. 200-19, 1990.
- [14] V. Vedral, *Decoding Reality: The Universe as Quantum Information: The Universe as Quantum Information*. OUP Oxford, 2012.
- [15] C. Liu, "Classical spontaneous symmetry breaking," *Philosophy of Science*, vol. 70, no. 5, pp. 1219-1232, 2003.
- [16] D. LAYZER, "Cosmogenesis- the growth of order in the universe(book)," *New York, Oxford University Press, 1990, 330, 1990*.
- [17] J. Collier, "Rhythmic entrainment, symmetry and power," *Explorations in*, 2007.
- [18] B. Van Fraassen, *Laws and symmetry*. Oxford University Press New York, 1989.
- [19] M. Tribus and E. McIrvine, "Energy and information," *Scientific American*, vol. 225, no. 3, pp. 179-188, 1971.
- [20] S. Toyabe, T. Sagawa, M. Ueda, E. Muneyuki, and M. Sano, "Experimental demonstration of information-to-energy conversion and validation of the generalized Jarzynski equality," *Nature Physics*, vol. 6, no. 12, pp. 988-992, 2010.
- [21] R. M. Barnett, H. R. Quinn, and H. Mühry, "Carriers of force," in *The Charm of Strange Quarks*, pp. 71-84, Springer, 2000.
- [22] I. V. Sokolov, N. M. Naumova, J. A. Nees, and G. A. Mourou, "Pair creation in qed-strong pulsed laser fields interacting with electron beams," *Physical review letters*, vol. 105, no. 19, p. 195005, 2010.
- [23] E. Sather, "The mystery of the matter asymmetry," *Beam Line*, vol. 26, pp. 31-37, 1996.
- [24] L. DiCarlo, M. Reed, L. Sun, B. Johnson, J. Chow, J. Gambetta, L. Frunzio, S. Girvin, M. Devoret, and R. Schoelkopf, "Preparation and measurement of three-qubit entanglement in a superconducting circuit," *Nature*, vol. 467, no. 7315, pp. 574-578, 2010.